

Energy-Efficient Windows

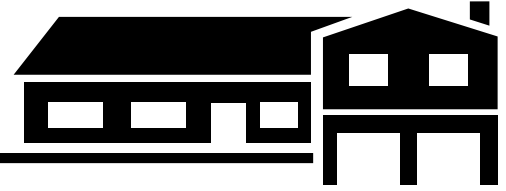

January 2000

Introduction

When purchasing a new home, homeowners want their home to be correct in every detail while costing as little as possible. However, savings to a homeowner can also occur even after the home is purchased, by using energy-efficient components as the home is being constructed. One example involves a homeowner's choice of energy-efficient windows which have a tremendous impact on energy performance (and costs!) of heating and cooling a home, as well as the seasonal comfort level experienced by the home's occupants. While energy-efficient windows will cost more initially, they often return their additional cost investment through substantial savings to the homeowner on monthly energy bills.

Installation of energy-efficient windows is just one area where homeowners can decrease their energy usage, save money, and help the environment all at the same time. Other areas range from having the correct (cost-effective) level of insulation in a home's walls, ceilings, and floors to simple, periodic maintenance of the furnace and air-conditioning system. Investing in energy-efficient options provides a continued payback not only in dollars and cents, but also in a more enjoyable and comfortable living environment for your family for many years.

Purpose of this fact sheet

This fact sheet will help new-home buyers make informed decisions about selecting energy-efficient windows and will assist owners of existing homes understand the benefits of energy-efficient windows.

The impact of windows on the overall energy consumption of a home

Windows provide less resistance to heat flow than walls, ceilings, and floors of your home. Even when windows comprise a small area of a home, they are the area of greatest heat loss and gain, and air leakage. Windows can account for as much as 25-30% of the heat loss in a home. This increases energy use and costs, and decreases your comfort.

The performance of windows, walls, ceilings, and other building components determine the monthly energy cost as well as the required size of your heating and cooling equipment. The installation of energy-efficient windows (as well as other aspects of a home's construction) reduces not only your monthly energy use (and costs) but also means that a smaller, less expensive furnace and air-conditioning system will be required. Therefore, while energy-efficient windows will cost more initially, the monthly savings on your energy bills coupled with a reduction in the purchase price of the heating and cooling system, can more than offset the higher initial cost.



Engineering Extension

Energy performance characteristics of windows

A window's ability to resist heat flow, its insulating value, is defined by its R-value or U-factor. The U-factor is the reciprocal of the R-value ($R=1/U$). The larger the U-factor the greater the heat flow through the window. Glass by itself is an extremely poor insulator. A single-pane window of clear glass has an R-value of around 1 ($U=1/R$ (U-value =1) while double-glazed units have R-values of 2 (U-factor=0.5).

To help alleviate confusion associated with window energy performance and ratings, the National Fenestration Rating Council (NFRC) has developed a window rating system based on whole window performance. The NFRC rating accurately accounts for all product components and presents window information in a concise and easy-to-understand format.

The NFRC energy ratings take into account the window's resistance to heat flow (U-factor), the amount of heat admitted as radiant energy (solar heat gain coefficient, SHGC), and the amount of visible transmittance (VT). In the future, NFRC ratings will include ratings for air infiltration (leakage), heating and cooling performance, condensation, and long-term energy performance. A typical NFRC rating label for an example window is presented below along with the new NFRC rating logo.



National Fenestration Rating Council

CERTIFIED

World's Best Window Co.

Millennium 2000+ Casement
CPD#000-x-000

Vinyl-Clad Wood Frame • Double Glaze
Argon Fill • Low E • Solar Control Coatings

ENERGY Performance

- Energy savings will depend on your specific climate, house and lifestyle
- For more information, call 1-800-123-4567 or visit NFRC's web site at www.nfrc.org

		Technical Information		
Res	U-Factor	.32	Solar Heat Gain Coefficient	.45
	Visible Transmittance			.58
Non-Res	U-Factor	.31	Solar Heat Gain Coefficient	.45
	Visible Transmittance			.60

Manufacturer stipulates that these ratings conform to applicable NFRC procedures for determining whole product energy performance. NFRC ratings are determined for a fixed set of environmental conditions and specific product sizes.

Windows have two U-factor ratings: one for the center of the glass and one for the total window assembly which includes edge-of-glass and frame effects (overall U-factor). Center-of-glass U-factor is the U-factor for the glass alone and the overall U-factor accounts for heat flow through the glass itself, the edges that occur in the unit, and the window frame and sash. NFRC rating is for the whole window. Windows should be compared with an overall U-factor. In addition, the NFRC label includes ratings for both residential and non-residential windows. Non-residential windows generally have larger areas where the edge effects are less pronounced than residential windows. Overall, or whole-window, U-factors for most commercially available windows range from 0.3 for a double-glazed, low-e window assembly to 1.00 to 1.30 for a single-glazed clear window assembly.

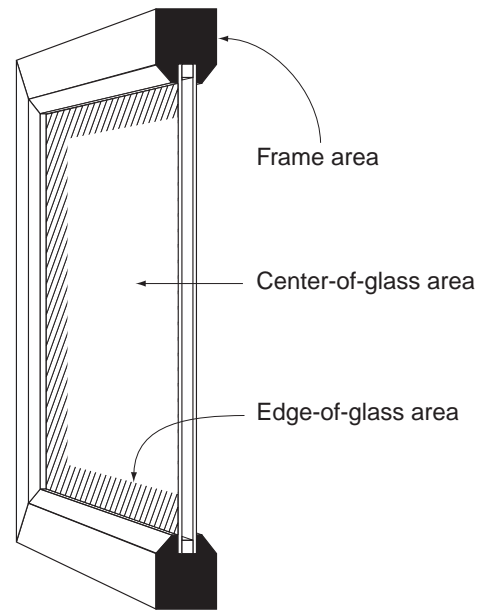

The solar heat gain coefficient (SHGC) refers to the fraction of solar radiation that passes through a window assembly and warms the interior living spaces of a home. The SHGC is expressed as a number between 0 and 1 with a low SHGC meaning a lower amount of solar heat is transmitted. The higher the SHGC, the greater the amount of passive solar gain by the interior of the home, which is important in heating dominated climates (cold weather locations). For warm climate locations, a SHGC of 0.4 or less is recommended. Double-glazed windows can have a SHGC from 0.3 to 0.75, while standard single-pane

windows generally have values greater than 0.8. Visible transmittance (VT) is an optical property of the window pane defined as the fraction of visible light transmitted through the glazing material. It is influenced by the glazing type, number of layers, and any coatings applied to the glazing. VT does not affect the heating and cooling loads. The higher the VT, the more daylight transmitted through the pane(s). A high VT is desirable for locations in which daylighting is important. VT ratings based on the total window assembly range from 0 to 1, with single-glazed clear glass having a rating around 0.69 and double-glazed units having VT's from 0.51 to 0.62.

Heat gain and loss can occur not only from the transfer of thermal radiation through a window, but also from the leakage of air around the edges and spacings of the window frame. The infiltration of air around a window pane and frame is indicated by an air leakage rating (AL) expressed in cubic feet of air per square foot of window area (ft^3/ft^2). The lower the AL rating, the lower the air infiltration around the window. An AL of 0.30 or less is recommended. Air infiltration is a function of the style and sealing characteristics of the window assembly. AL ratings vary from 0.98 for single-glazing clear windows to 0.10 for double-glazed units.

Types and characteristics of energy-efficient windows

Glazing is defined as the glass or plastic panes in a window assembly and most windows in U.S. residences contain glass. Technological advances in recent years have improved the energy performance, and mechanical and chemical characteristics of glazing materials. Plastic glazing is used primarily in specialized applications.

Single clear glazing

A single-glazed clear window is the most common window type in existing residences. Of all the glazing options, a single-glazed unit allows the greatest heat loss in the winter and the most heat gain in the summer. It also allows the most daylight transmis-

sion. Because single-glazed units are the least energy-efficient of all window types, they are used as the base case for comparisons to other more efficient units.

Tinted glazing

Tinted glass is made by altering the chemical composition of the glass with chemical additives. Primary uses for tinted glass are to reduce glare and solar heat gain. Glass that is tinted also reduces visible light transmittance. Some tints, referred to as spectrally selective, allow a greater amount of daylight to pass through the glazing while at the same time decrease the heat gain from sunlight. Applications for tinted glass are almost entirely in commercial buildings and primarily in warmer climates where reduction of solar heat gain is a concern.

Multiple-pane glazing

In double-glazing window units, two layers of glass are separated by a spacer. This provides increased thermal resistance to winter heat loss and summer solar heat gain. With double glazing, the visible light transmittance is only slightly diminished. Tests show that the best thermal performance occurs when the spacing between the glazings is about 1/2 inch.

Another way of improving thermal performance of multiple-glazed units is to fill the space between the panes with an argon or krypton gas, both of which are much less conducting than air. Both gases are inert, non-toxic, odorless, and clear. Krypton has better thermal performance properties, but does cost more. Specially designed spacers help reduce heat loss through the window edge. Sealing of double glazings to maintain the argon or krypton is a well-proven technology and should last for several decades.

One advantage of using gas fills versus plastic films for multiple pane units is that the visible light transmittance is not affected. Because sealing of windows is not perfect, an expected loss of some of the gas over several decades is to be expected, but will only result in a few percentage points decrease in the overall U-factor.

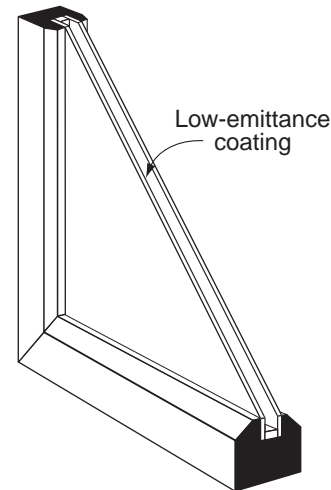
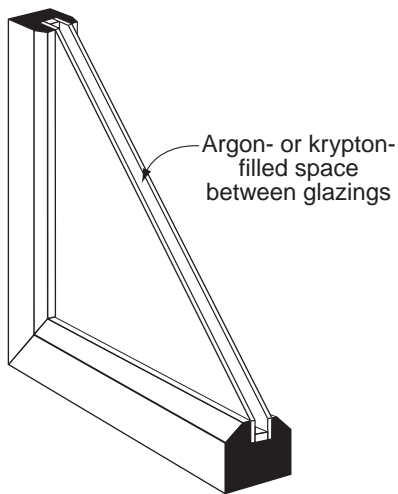
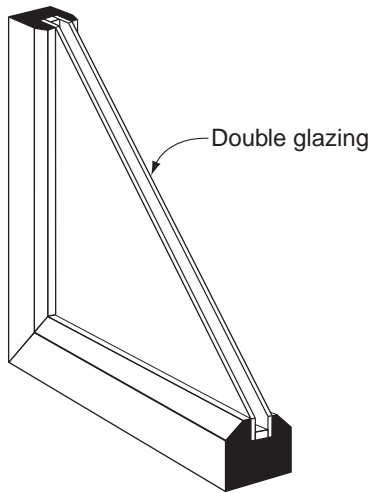

Addition of a second pane to a window assembly doubles the thermal resistance. If a third or fourth pane is added, the thermal resistance also increases, but with a diminishing effect. The trade-off with multiple panes is that while thermal resistance is increased with each pane, visible light transmittance decreases as well as the solar heat gain in the winter months. In addition, more panes also add to the initial cost which may not be recovered over the life of the window.

Low-emissivity (low-e) coatings

Low-emissivity or low-e coatings refer to a microscopically thin, transparent layer of metal or metal oxide applied to a window glazing to reduce the

transfer of heat through window glazings while allowing the full amount of sunlight to pass through. Emissivity is defined as the window glazing's ability to radiate energy or heat. Emissivities of window glazings range from 0 to 1. The lower the emissivity of a window glazing, the lower the amount of heat radiated to another surface.

Standard clear glazings have an emissivity value of about 0.85, meaning that 85% of the heat absorbed by the window pane will be radiated through it either to the interior of the home (summertime) or to the outside (wintertime). By contrast, double-glazed windows with low-e coatings have emissivity value of between 0.05 to 0.20, implying that as much as 95% of the heat will be reflected from the window surface. In wintertime, low-e coatings are used to reflect heat back to the interior living spaces of your home, while in the summertime they reflect heat back to the outside. Low-e coated windows generally cost 10 to 20% more than standard clear-glazed ones, but can save 30 to 50% on energy costs associated with the window assembly throughout their lifetime.

Thermally improved edge spacers

In multiple-pane units, the glazing layers must be held apart by edge spacers. These spacers must accommodate expansion and contraction of the glazing layers due to seasonal temperature differences, provide a moisture barrier and a gas-tight seal, and create an insulating barrier to prevent unwanted heat gain or loss.

In the past, most edge spacers were manufactured from aluminum, but since aluminum has such a high thermal conductivity, edge losses tended to offset the benefits of multiple glazings. In addition, colder aluminum edge spacers were more prone to condensation. Thermally improved edge spacers incorporate new materials and designs to improve performance. Stainless steel spacers are now used because they are less conducting than aluminum. All new edge spacer technologies are designed to interrupt the heat transfer between the glazing edge and the glazing itself. These improved edge spacers help maintain a higher temperature at the edge of the window unit, thereby decreasing the potential for condensation. The most common new design is to use a spacer, sealer, and a desiccant in a single-tape element. Other new, improved edge spacer technologies include butyl tape or silicone foam, and aluminum spacers with thermal breaks.

Condensation

Energy-efficient windows can help control condensation because they keep interior glass surfaces and window frames warmer. This in turn helps the home retain more of the warmth provided by the furnace, which will keep the walls and windows of the home warmer, thereby reducing the potential for condensation.

As an example of the ability of energy-efficient windows to control condensation, when the outdoor temperature is 10 degrees Fahrenheit, condensation will occur on a single-glazed clear glass window when the relative humidity of the home is as low as 15%. If a double-glazed energy-efficient window is installed, the relative humidity could be 3 times that amount before condensation would occur and nearly 4 times if double-glazed, low-emissivity, argon gas-filled windows are used.

Site planning and overhangs

While the selection of energy-efficient windows can help lower monthly energy bills, other energy-efficiency considerations need be taken into account when planning a new home. Some homes, due to the placement of their windows, may be difficult to

shade architecturally. Landscaping and use of overhangs can influence the total energy performance and consumption of your home.

Planting broad-leafed trees in locations that will shade your east and west windows during the day in the summer months will reduce solar heat gain but still allow sunlight through the windows during winter. Also, use of shrubs and other foliage as windbreaks will help reduce wind speeds and unwanted cold air infiltration into your home.

On southern exposures, one of the best ways to decrease summer solar heat gain is with overhangs. There are two different types of overhangs: fixed and moveable. Fixed overhangs refer to the portion of your roof that provides shade to the window. The length of the overhang required to provide full shade in the summertime can be determined and built to these specifications during construction. Moveable overhangs can be temporarily attached above or to the side of the window to block high-angle summer sunlight.

Financing energy-efficient windows and energy-efficient mortgages

Energy-efficient windows will typically cost more than conventional windows (clear-glazed, aluminum frame) and will be financed with the home's mortgage or some other sort of long-term financing that distributes the payments over an extended period of time (15 to 30 years). However, monthly savings that result from installation of energy-efficient windows (and other energy-savings measures) may offset all or a significant fraction of the homeowner's additional monthly payment.

Energy-efficient mortgages (EEM) allow homeowners to qualify for a larger mortgage because the combination of their monthly mortgage payment plus their monthly utility bill will be less than their payments for a non energy-efficient home. To qualify, the home must be rated a 4 Star Home with the Home Energy Rating System (HERS) or meet the 1993 Model Energy Code (MEC). An EEM also allows homeowners to finance the purchase of energy-efficient improvements as part of their first

mortgage. Contact your state energy office for more information or visit this web-site at www.pueblo.gsa.gov/press/eemguide.htm.

Selecting an energy-efficient window for your home

Climate, the total window area of your home, landscaping, the type of heating and cooling system, and the level of insulation in your home all play a role in determining the type of energy-efficient window that is most cost-effective. Just because one energy-efficient window has better thermal/energy performance properties, such as lower U-factors or SHGC's than another one, does not mean that it will be the most cost-effective window to install. When selecting energy-efficient windows, start with the following:

Look for the Energy Star label

This label signifies and insures the window is energy efficient and has met certain U.S. Department of Energy and U.S. Environmental Protection Agency energy performance criteria.



Look for the NFRC label

This label can be used to make comparisons between windows. The NFRC label is the only reliable and proven way to determine the basic energy-related properties of the window unit and compare them.

Determining the most cost-effective, energy-efficient window

Following is a simple example associated with determining the most cost-effective window to install in a new two-story home in Kansas City, given three different commercially available common window choices.

The windows considered were as follows:

1. Aluminum frame, single-glazed, clear (window #1)
2. Aluminum frame, double-glazed, clear (window #2)
3. Wood/Vinyl frame, double-glazed, low-e, argon-filled (window #3)

The home has ten windows and the home's annual heating and cooling costs have been estimated to be \$978 (window #1), \$828 (window #2), and \$659 (window #3), respectively, for the three window types which cost \$100, \$150, and \$175 per window installed, respectively.

On first glance, it would appear that window #3 is the best choice since its installation provides the lowest annual heating and cooling costs. However, other considerations must be taken into account when determining which window is actually the most cost-effective. These include the initial cost associated with each window choice, cost of maintenance (if any), and expected life of the window.

Most energy-efficient window purchases on new homes are financed through the homeowner's mortgage payment at a particular interest rate, which is assumed to be 8% in this example, and all three windows are expected to last 20 years with negligible maintenance. A simple way to determine which of the three windows is most cost-effective is to calculate the additional cost to the homeowner's mortgage payment associated with installing one window choice versus another and compare this cost to the annual energy savings attained by that particular window. This is demonstrated as follows:

The annual energy savings using window #2 versus window #1 is \$150 (\$978 minus \$828) and the increase in cost is \$500 between the two windows (\$150 per window for window #2 versus \$100 per window for window #1 and there are ten windows). The \$500 increase financed in the homeowner's mortgage payment at 8% equates to an additional \$47 per year. Therefore, since the additional annual mortgage payment (\$47) is less than the annual energy savings (\$150) derived by installing window #2, window #2 is more cost-effective than window #1.

Using the same logic, window #3 can be compared to window number #2. The annual energy savings is \$200 (\$894 minus \$694) and the total increase in cost between the two windows is \$250 (\$175 per window for window #3 versus \$150 per window for window #2 and ten windows). Using these values, there is roughly a \$24 increase in the homeowner's annual mortgage payment in order to achieve \$169 in energy savings. Since window #3 is more cost-effective than window #2 and window #2 was better than window #1, window #3 is the most cost-effective window of the three.

Estimated annual energy costs for five different residential window types

The following table presents estimated annual heating and cooling costs for both one- and two-story homes, three different heating and cooling cost scenarios, and five different residential window types located in each of three distinct Kansas zones (1, 2, or 3) shown on the map. The windows considered in this analysis are a single-glazed, clear and four other commercially available energy-efficient residential window types with aluminum (Al) or wood/vinyl

(W/V) frames. (Each is listed at the top of the table.) Assumptions used to obtain these estimates are listed at the bottom of the table. Use the low energy prices if you have natural gas heating and conventional air conditioning, an air-source heat pump with electric costs below \$.05 per kWh, or a water-source heat pump with electric costs below \$.08 per kWh. Use the medium energy prices if you use propane in combination with a conventional air conditioner, an air-source heat pump with electric costs below \$.07 per kWh, or a water-source heat pump with electric costs below \$.12 per kWh. Use the high energy prices if electric costs exceed those listed above or if you use electric-resistance heating.

Kansas climate zones

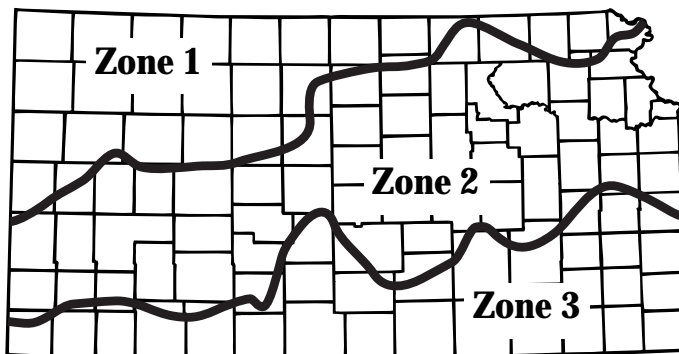

Estimated average annual heating and cooling costs for five window types

General Window Description	One-Story					Two-Story				
	Al, single-glazed, clear	Al, double-glazed, clear	Al, double-glazed, clear, thermal break	W/V, double-glazed, clear	W/V, double-glazed, low-e, argon-filled	Al, single-glazed, clear	Al, double-glazed, clear	Al, double-glazed, clear, thermal break	W/V, double-glazed, clear	W/V, double-glazed, low-e, argon-filled
Low Energy Prices										
Zone 1	\$514	\$429	\$401	\$371	\$345	\$737	\$608	\$566	\$521	\$478
Zone 2	\$481	\$413	\$388	\$362	\$331	\$696	\$594	\$556	\$516	\$468
Zone 3	\$420	\$359	\$337	\$314	\$287	\$613	\$522	\$488	\$453	\$410
Medium Energy Prices										
Zone 1	\$770	\$639	\$598	\$554	\$519	\$1,094	\$897	\$834	\$767	\$713
Zone 2	\$686	\$583	\$547	\$509	\$472	\$978	\$828	\$775	\$717	\$659
Zone 3	\$599	\$505	\$474	\$440	\$407	\$868	\$728	\$680	\$628	\$576
High Energy Prices										
Zone 1	\$1,398	\$1,174	\$1,102	\$1,026	\$959	\$1,997	\$1,654	\$1,544	\$1,427	\$1,323
Zone 2	\$1,156	\$1,001	\$948	\$890	\$828	\$1,655	\$1,421	\$1,338	\$1,251	\$1,155
Zone 3	\$1,016	\$869	\$819	\$765	\$708	\$1,477	\$1,253	\$1,176	\$1,094	\$1,005

Assumptions: one-story house 1,500 ft² floor area, two-story house 2,250 ft²; for each, window area 15% of floor area, ceiling insulation R-30, wall and floor insulation R-19, heating system efficiency 78%, and a 10 SEER.

Estimates in this table were made using the RESFEN (Residential Fenestration) energy-efficient windows computer simulation model available at www.windows.lbl.gov/software/resfen_getcopy_31.htm.

Using these total energy estimates, locally obtained installed-window costs, and the guidelines and methodology outlined in the example in the previous section, you should be able to determine the most cost-effective, energy-efficient window for the zone in which you live.

Summary

Windows have a tremendous effect on the heating and cooling requirements and costs of a home, as well as the comfort level experienced by its occupants. Windows are by far the weakest link in a home's building envelope for heat gain in the summertime and heat loss in the wintertime. Glazing type, number of glazings, window frame materials and design, interior and exterior shading, and window orientation all contribute to the energy performance of your home and to your choice of energy-efficient window. Therefore, it is extremely important to carefully consider all options when determining which energy-efficient window is best and most cost-effective for your needs both now and in the future. It does make a difference to use energy-efficient windows—in cost savings to you, the homeowner, in energy savings to our country, and as a benefit to our environment.

Further information

The following Web sites offer additional facts and information on energy-efficient residential windows:

- www.efficientwindows.org
- www.nfrc.org
- www.eren.doe.gov/erec/factsheets/eewindows.html

Also, an excellent book on energy-efficient residential windows is *Residential Windows* by John Carmody, Stephen Selkowitz, and Lisa Hescong published by Norton.

For questions regarding this fact sheet or further information on energy-efficient windows, please contact Engineering Extension Programs at 785-532-6026. This fact sheet is posted on the Kansas State University Engineering Extension Web page at www.oznet.ksu.edu/dp_nrgy/ees. Other KSU Engineering Extension Fact Sheets posted at this site include the following:

- Tips for Purchasing an Energy-Efficient Home
- Foundation Insulation
- Selecting a Home Heating System
- Selecting a Home Cooling System
- Energy-Efficient Mortgages
- Residential Insulation
- Air Sealing Your Home



Printed on recycled paper

"This material was prepared with the support of the U. S. Department of Energy (DOE) Grant No. DE-FG48-97R802102. However, any opinions, findings, conclusions, or recommendations expressed herein are those of the author(s) and do not necessarily reflect the views of DOE."



Notice of Nondiscrimination

Kansas State University is committed to a policy of nondiscrimination on the basis of race, sex, national origin, disability, religion, age, sexual orientation, or other nonmerit reasons, in admissions, educational programs or activities, and employment (including employment of disabled veterans and veterans of the Vietnam Era), all as required by applicable laws and regulations. Responsibility for coordination of compliance efforts and receipt of inquiries, including those concerning Title IX of the Education Amendments of 1972, Section 504 of the Rehabilitation Act of 1973, and the Americans with Disabilities Act, has been delegated to Jane D. Rowlett, Ph.D., Director of Unclassified Affairs and University Compliance, Kansas State University, 225 Anderson Hall, Manhattan, KS 66506-0124 (785-532-4392).